

Cast Steel Gate Valve

Class 300 Flanged (2" to 36") - 30FGAW

Class 300 Butt Weld (2" to 24") - 30BGAW

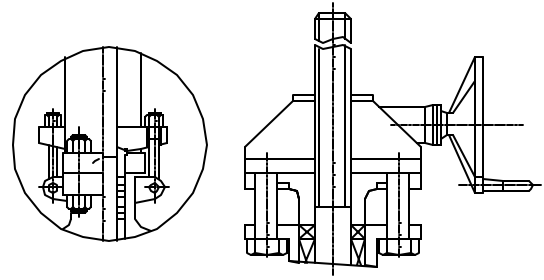

12" & Larger

Gear Operator

NO.	PART NAME	MATERIAL
1	BODY	A216 WCB
2	SEAT	A105+HF
3	WEDGE	WCB+F6
4	STEM	A182 F6
5	GASKET	Spiral Wound S5/Graphite
6	BONNET	A216 WCB
7	BACK SEAT	A276 410
8	PACKING	Graphite
9	DISTANCE RING	A276 410
10	PACKING GLAND	A276 410
11	GLAND	A216 WCB
12	STEM NUT	D-2 Ductile Iron
13	GLAND NUT	A29 1D35 Steel
14	LOCK NUT	A29 1D35 Steel
15	HANDWHEEL	Ductile Iron
16	GREASE FITTING	Steel
17	EYE BOLT	A193 B7 Steel
18	EYE NUT	A194 2H Steel
19	PIN	A29 1D35 Steel
20	BOLT	A193 B7 Steel
21	NUT	A194 2H Steel

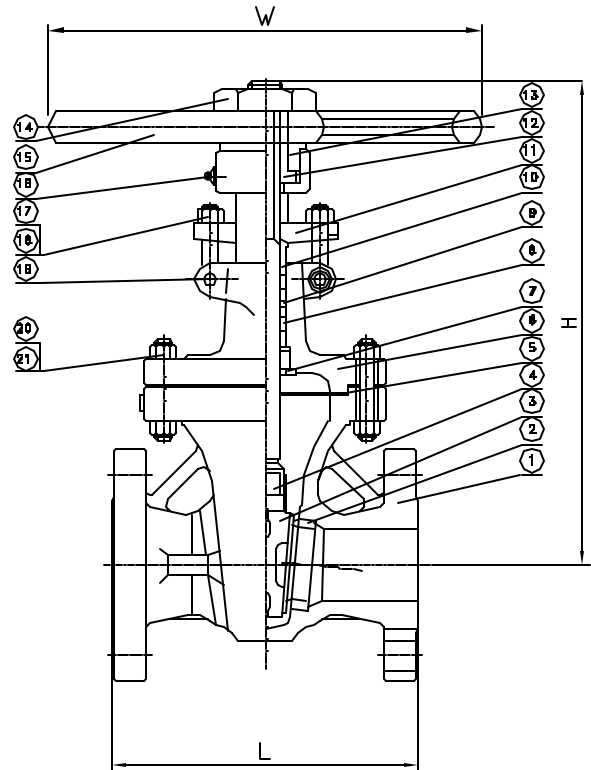

Davis cast steel valves comply with the following applicable specifications: ANSI B16.10, ANSI B16.5, API 600: Tested to API 598

Working Pressure: 740 WOG Body Testing Pressure: 1110 psi
Seat Testing Pressure: 814 psi Air Testing Pressure: 80 psi

NPS d	in	2	2-1/2	3	4	5	6	8	10	12	14	16	18	20	24	30	36
	mm		51	64	76	102	127	152	203	254	305	337	387	432	483	584	737
L (RF & BW)	in	8.5	9.5	11.12	12	15	15.88	16.5	18	19.75	30	33	38	39	45	55	68
	mm		216	241	283	305	381	403	419	457	502	572	610	660	711	1143	1397
H (open)	in	16.42	18.11	20.71	25.59	27.32	32.44	38.86	46.93	56.34	61.38	69.21	76.46	84.45	102.44	138.0	156
	mm		417	460	526	650	694	824	987	1192	1431	1559	1758	1942	2145	3602	3505
W	in	7.87	9.84	9.84	9.84	11.81	13.78	17.72	19.69	22.05	18.11	18.11	24.02	24.02	Gear	Gear	Gear
	mm		200	250	250	250	300	350	450	500	560	460*	460*	610*			
WT (Lbs)	RF	66	86	121	183	203	302	529	734	1182	1541	2227	2657	3792	7529	10817	15300
	BW	57	75	104	150	170	260	430	597	952	1312	1870	2260	3219	6737	-	-

* Manual gear operator is recommended.

